

2. MACHINE SPECIFICATIONS

2.1. STANDARD SPECIFICATIONS

(1) TABLE

TABLE SIZE	$\phi 630 \times 500\text{mm}$ ($\phi 24.8'' \times 19.7''$)
T SLOT (WIDTH \times LENGTH)	18mm \times 3 (0.7" \times 3)
MAX.WORK SIZE	$\phi 630 \times 500\text{mm}$ ($\phi 24.8'' \times 19.6''$)
TABLE LOAD CAPACITY	400 kg (880 LBS)
DISTANCE FROM FLOOR TO TABLE SURFACE	785(30.9 inch)

(2) TRAVEL

LONGTUDINAL TRANEL (X AXIS)	815 mm (32")
CROSS TRAVEL (Y AXIS)	745 mm (29.3")
(ATC STROKE	+255 mm (+10.0"))
VERTICAL TRAVEL (Z AXIS)	500mm (19.6")
TABLE TILTING (A-AXIS)	150° (-120° \sim +30°)
TABLE TILTING (C-AXIS)	360°
DISTANCE FROM TABLE SURFACE TO SPINDLE NOSE (A=0°)	100 \sim 600 mm (3.9" \sim 23.6")

(3) SPINDLE

SPINDLE TAPER	NST. NO. 40
SPINDLE SPEED	20 \sim 20,000 min ⁻¹
DIRECTLY SPECIFIED BY A 5 DIGIT S CODE	

(4) FEED

RAPID FEED	X AND Y AXIS (AUTO)	50,000 mm/min. (1968.5 inch/min.)
		(MANUAL) 15,000 mm/min. (590.6 inch/min.)
	Z AXIS	(AUTO) 25,000 mm/min. (984.2 inch/min.)
		(MANUAL) 15,000 mm/min. (590.6 inch/min.)
CUTTING FEED X, Y AND Z AXIS		0-25,000 mm/min. (0-984.2 inch/min.)
RAPID FEED	A AXIS (AUTO)	2,000 deg/min
	C AXIS (AUTO)	6,000 deg/min

Mytrunnion

(5) ATC

TOOL STORAGE CAPACITY 50 TOOLS (OP. 100)
TOOL SELECTION METHOD
RANDOM, TOOL IDENTIFIED AT MAGAZINE
TOOL SHANK NST NO.40
MAX. TOOL SIZE ϕ 75 \times 300 mm
(ϕ 2.95" \times 11.8")
-TWO NEIGHBORING TOOL POTS SHOULD BE EMPTY: ϕ 150 \times 300 mm
(ϕ 5.91 \times 11.8 inch)
MAX. TOOL WEIGHT (WITH TOOL HOLDER) 10kg (22 LBS)

(6) MOTOR

SPINDLE MOTOR (30 min. RATIO) AC 13 KW
(CONTINUOUS OPERATION) AC 7.5 KW
COOLANT MOTOR AC 0.73(50Hz)
/1.21(60Hz) KW
LUBRICATION PUMP AC 20 KW

(7) MACHINE WEIGHT WITH NC

17,400 kg (38,280 LBS)

(8) ELECTRIC POWER SOURCE

MAIN CIRCUIT THREE PHASE CURRENT AC 200/220 V
(If the machine has a trance former, this is
secondary voltage.)
FREQUENCY 50/60 Hz
CONTROL CIRCUIT SINGLE PHASE CURRENT AC 100 V
(Made from AC 200/220 V by a trance former.)
DIRECT CURRENT DC 24 V

2.2. STANDARD ACCESSORIES

- | | |
|-------------------------------|-------|
| 1 : Leveling bolts and plates | 1 set |
| 2 : Cutting fluid device | 1 set |

2.3. OPTIONAL ACCESSORIES

- 1: Foundation bolt
- 2: Illumination unit
- 3: Warming-up timer
- 4: Machining finish indicator lamp
- 5: Weekly timer
- 6: Run hour display
- 7: Oil mist coolant device
- 8: Automatic tool breakage sensor
- 9: Automatic power stop
- 10: Special color
- 11: Tool holders with pull studs (N.S.T. 40)

Spring collet

Collet

Pull stud

2.4 NC STANDARD SPECIFICATIONS

FANUC 16iM

NO.	SPECIFICATIONS
F6501	Controlled axis (3 axes)
F6502	Simultaneously controlled axes expansion
F6503	Tangential speed constant control
F6504	Least input increment 0.001mm / 0.001inch
F6507	Cutting feedrate clamp
F6508	Linear acceleration / deceleration before cutting feed interpolation
F6509	Fine Acceleration & Deceleration control
F6510	HRV control
F6511	Follow-up
F6512	Simple high-precision contour control
F6513	Automatic acceleration / deceleration
F6514	Automatic coordinate system setting
F6515	Manual reference position return
F6516	Buffer register
F6517	Program number
F6518	Sub program call
F6521	Decimal point programming / pocket calculator type decimal point programming
F6522	Auxiliary function (S, T, M code)
F6524	Label skip
F6525	Optional block skip
F6526	Backlash compensation
F6527	Program number search
F6528	Sequence number search
F6530	Dry run
F6531	Single block
F6532	Automatic operation (memory)
F6534	MDI operation
F6535	Tape code (EIA / ISO)
F6537	Stored pitch error compensation
F6538	Auxiliary function lock
F6539	Machine lock (all axes)

NO.	SPECIFICATIONS
-----	----------------

F6540	Machine lock (Z axis)
F6541	Manual absolute on and off
F6542	Reader / puncher interface (RS232C)
F6546	Feedrate override (0 - 254%)
F6547	Rapid traverse override (1, 25, 50, 100%)
F6548	Jog override
F6549	Spindle override
F6550	Mirror image
F6551	Programmable mirror image
F6552	JOG feed
F6554	Manual handle feed (0.001, 0.01, 0.1)
F6555	Override cancel (M49 / M48)
F6556	Positioning (G00)
F6557	Linear interpolation (G01)
F6558	Circular interpolation (G02, G03)
F6560	Dwell (G04)
F6561	Exact stop (G09)
F6562	Reference position return (G28, G29)
F6563	Reference position return check (G27)
F6566	Canned cycles (G73, G74, G76, G77, G80~G89, G98, G99)
F6567	Absolute / incremental programming (G90 / G91)
F6568	Tool length compensation (G43, G44, G49)
F6569	Skip (G31)
F6570	High-speed skip
F6571	2nd reference position return (G30)
F6572	Helical interpolation (G02, G03)
F6573	Programmable data input (G10 / G11)
F6574	Stored stroke check 1
F6575	Cutter compensation C (G40, G41, G42)
F6576	Inch / metric conversion (G20, G21)

NO.	SPECIFICATIONS
-----	----------------

- F6580 Addition of workpiece coordinate system pair (48pair)
- F6581 Exact stop mode (G61)
- F6582 Automatic corner override (G62)
- F6583 Tool offset pairs (99 pair)
- F6586 Tool offset
- F6588 Tool length measurement
- F6589 Part program storage length 320m
- F6590 Number of registerable programs 200
- F6591 Custom macro B
- F6592 Data protection key
- F6593 Extended part program editing
- F6594 Background editing
- F6595 Tool life management
- F6597 Clock function
- F6598 Self-diagnosis function
- F6599 Periodic maintenance screen
- F6600 Maintenance information screen
- F6601 Alarm display
- F6602 Alarm history display
- F6603 Operation history display
- F6604 Help function
- F6605 Current position display
- F6606 Run hour and parts count display
- F6607 Actual cutting feedrate display
- F6608 Directory display and punch for each group
- F6910 Emergency stop

2.5. NC OPTINAL SPECIFICATIONS

FANUC 16iM

NO.	SPECIFICATIONS
F6001	Signal direction positioning (G60)
F6002	Cylindrical interpolation
F6003	Polar coordinate interpolation
F6004	Helical interpolation B
F6005	Hypothetical axis interpolation
F6006	One-digit F code feed
F6007	3rd / 4th reference position return
F6008	High-speed cycle cutting
F6009	Retract of high-speed cycle cutting
F6010	Program restart
F6011	Stored stroke check 2
F6012	Stored stroke check 3
F6013	Stroke limit check before move
F6014	Small-hole peck drilling cycle
F6015	Involute interpolation
F6016	Exponential interpolation
F6017	High-precision contour control
F6018	Interruption type custom macro
F6019	Addition of custom macro common variables
F6020	Playback
F6021	Scaling
F6022	Coordinate system rotation
F6023	Addition of workpiece coordinate system pair (300pairs)
F6024	Figure copy
F6025	Tool offset pairs 200pairs
F6026	Tool offset pairs 400pairs
F6027	Tool offset pairs 499pairs
F6028	Tool offset pairs 999pairs
F6029	Tool offset memory B
F6030	Tool offset memory C

NO.	SPECIFICATIONS
-----	----------------

- F6031 Addition of tool pairs for tool life management 512pairs
- F6032 3-dimensional cutter compensation
- F6033 Part program storage length 640m
- F6034 Part program storage length 1280m
- F6035 Part program storage length 2560m
- F6036 Part program storage length 5120m
- F6037 Number of registerable programs 400
- F6038 Number of registerable programs 1000
- F6039 Optional block skip (9pair)
- F6040 Machining time stamp

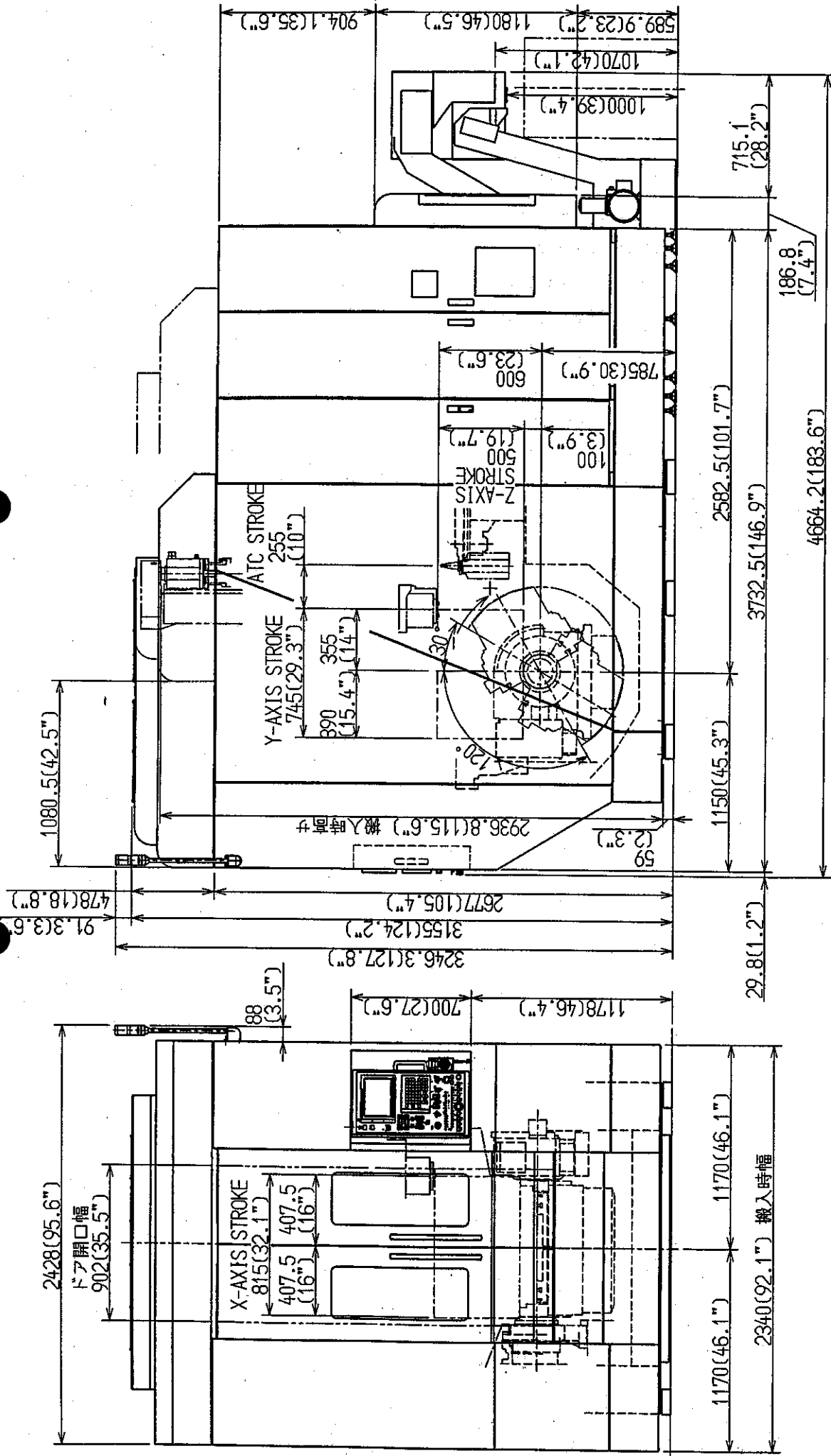

S003-013-2

100ATC

Mytrunnion OUTER VIEW OF MACHINE 外觀図
 KITAMURA MACHINERY CO.,LTD.

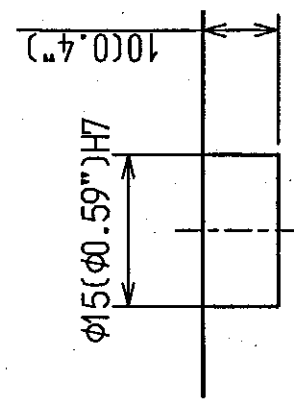
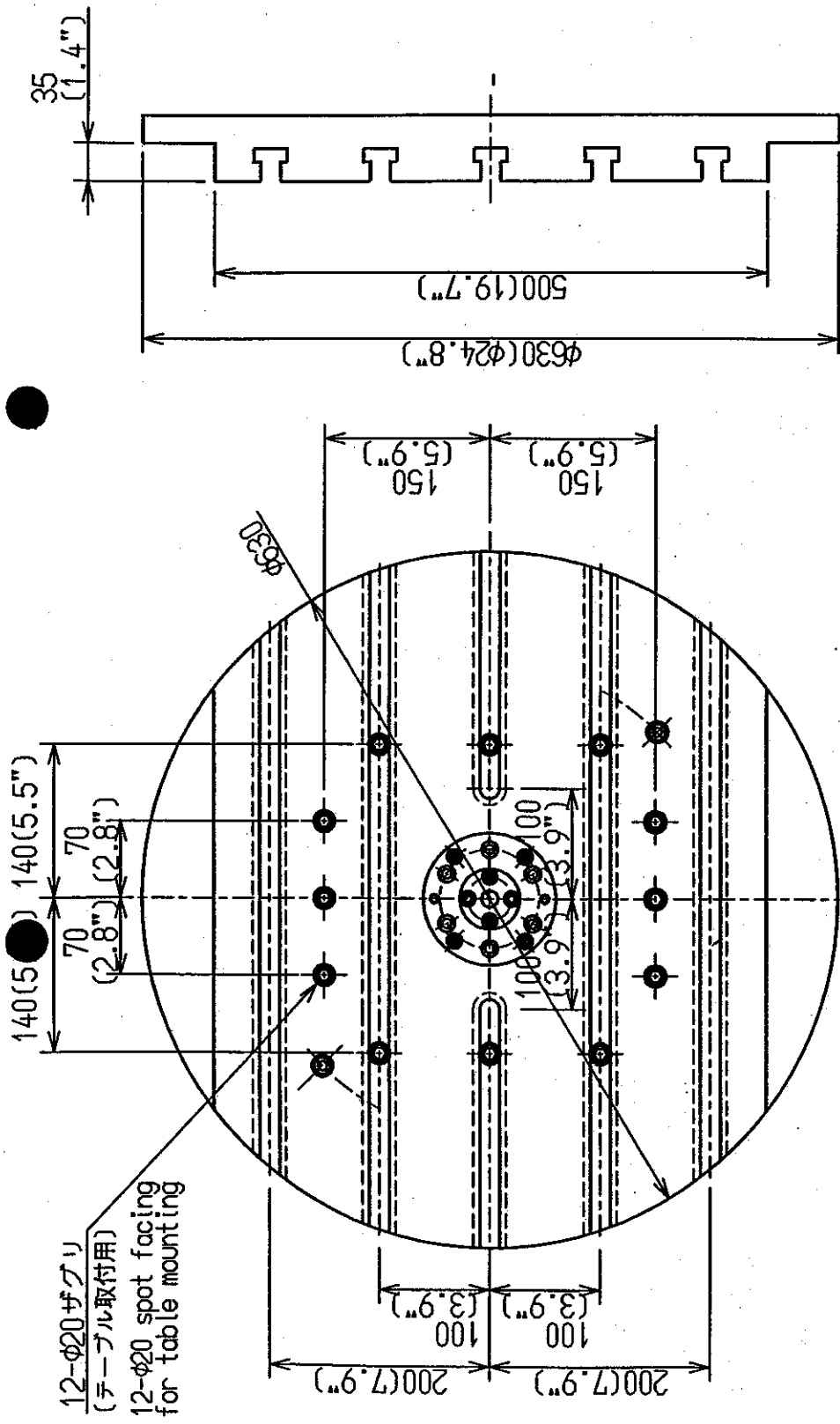

センター穴詳細
Sectional view of turntable

作業者側 (C軸 0° 時)
Operator side (C-axis, 0°)

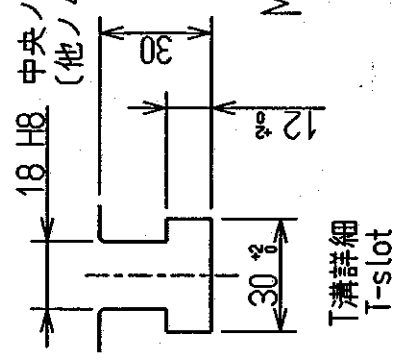

中央ノ1本ノニ (18H8 is only center slot)
(他ノ4本ハ18 H12) the other slots are 18H12)

Mytrunnion TABLE (テーブル)
KITAMURA MACHINERY CO., LTD.

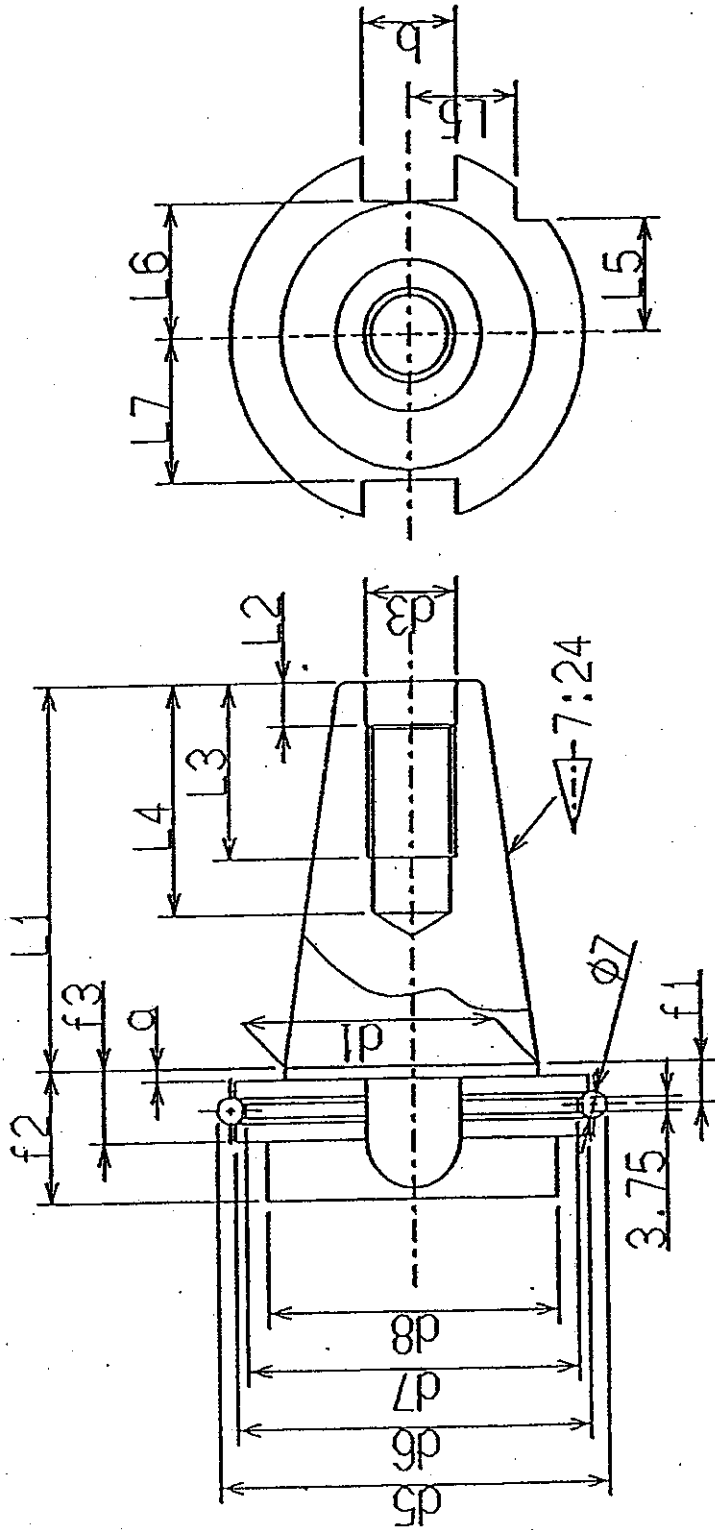

	a	b	d1	d2	d3	d4	d5	d6	d7	d8	f1	f2	f3	L1	L2	L3	L4	L5	L6	L7
	±0.1	H12			H7		±0.05	0	0		±0.1		0	0	+0.5			0	0	0
40	3.2	16.1	44.45	M16	17	19	72.3	63.55	56.25	50	11.1	35	19.1	68.4	8.2	32	42.5	18.5	22.8	25
50	3.2	25.7	69.85	M24	25	28	107.25	97.5	91.25	80	11.1	35	19.1	101.75	11.5	47	61.5	30	35.5	37.7

HOLDER DIN 69871
KITAMURA MACHINERY CO.,LTD.

6-B8SPSURU-4 92/06/01

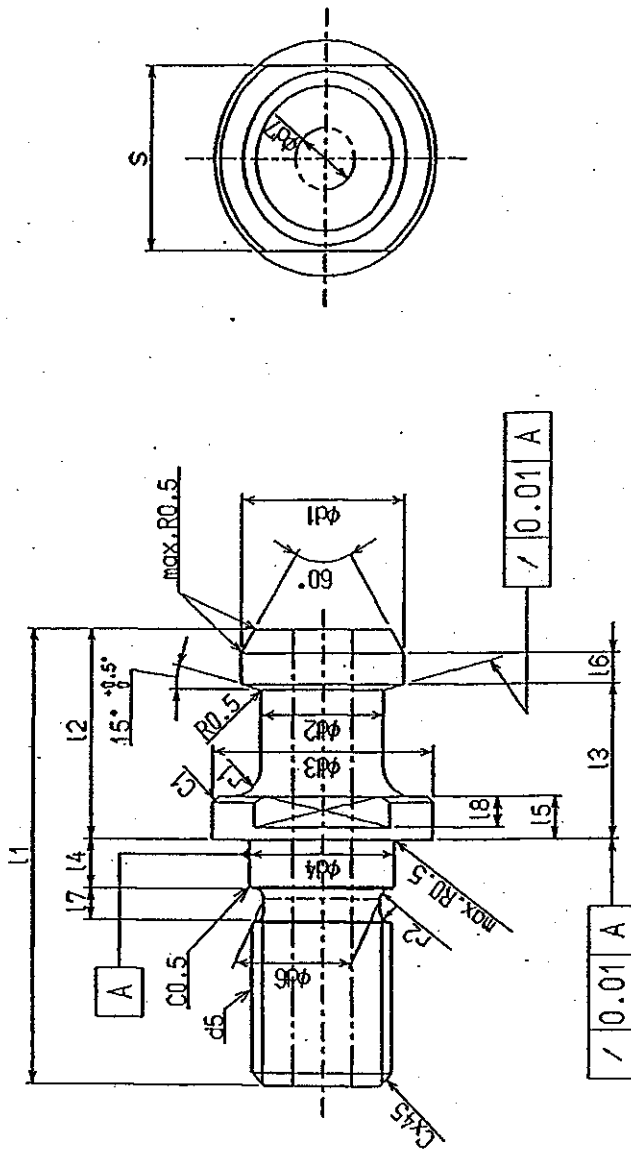

unit: mm

No.	l_1	d_4 h7	d_5 g9	C	r2	l_4	l_7	d_3 0 -0.2	r1	l_5 0 -0.1	s	d_1 0 -0.1	d_2 0 -0.1	l_2 0 -0.1	l_3 0 -0.1	16 d7	
40 P	54	17	M16	1.5	1	5	4	23	3	7	5	19	14	29	23	3	7
50 P	74	25	M24	2	1.5	8	5	38	5	7	5	30	21	34	25	5	10

JIS B 6339 PULL STUD
 KITAMURA MACHINERY CO., LTD.

S-R-NS-D111-ST111-2 06/11/99

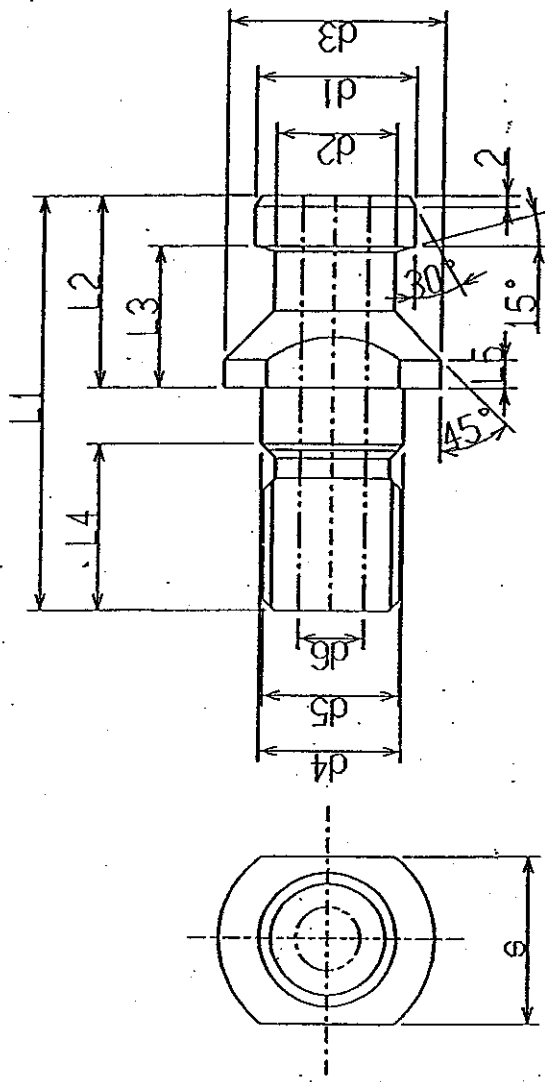

	d1	d2	d3	d4	d5	d6	L1	L2	L3	L4	L5	e
	0	0	0			+0.1		±0.1	±0.1			0
	-0.1	-0.1	-0.1			0						-0.1
40	19	14	23	17	M16	7	54	26	20	21	4	19
50	28	21	36	25	M24	11.5	74	34	25	30	5	30

PULL STUD DIN 69872
 KITAMURA MACHINERY CO., LTD.

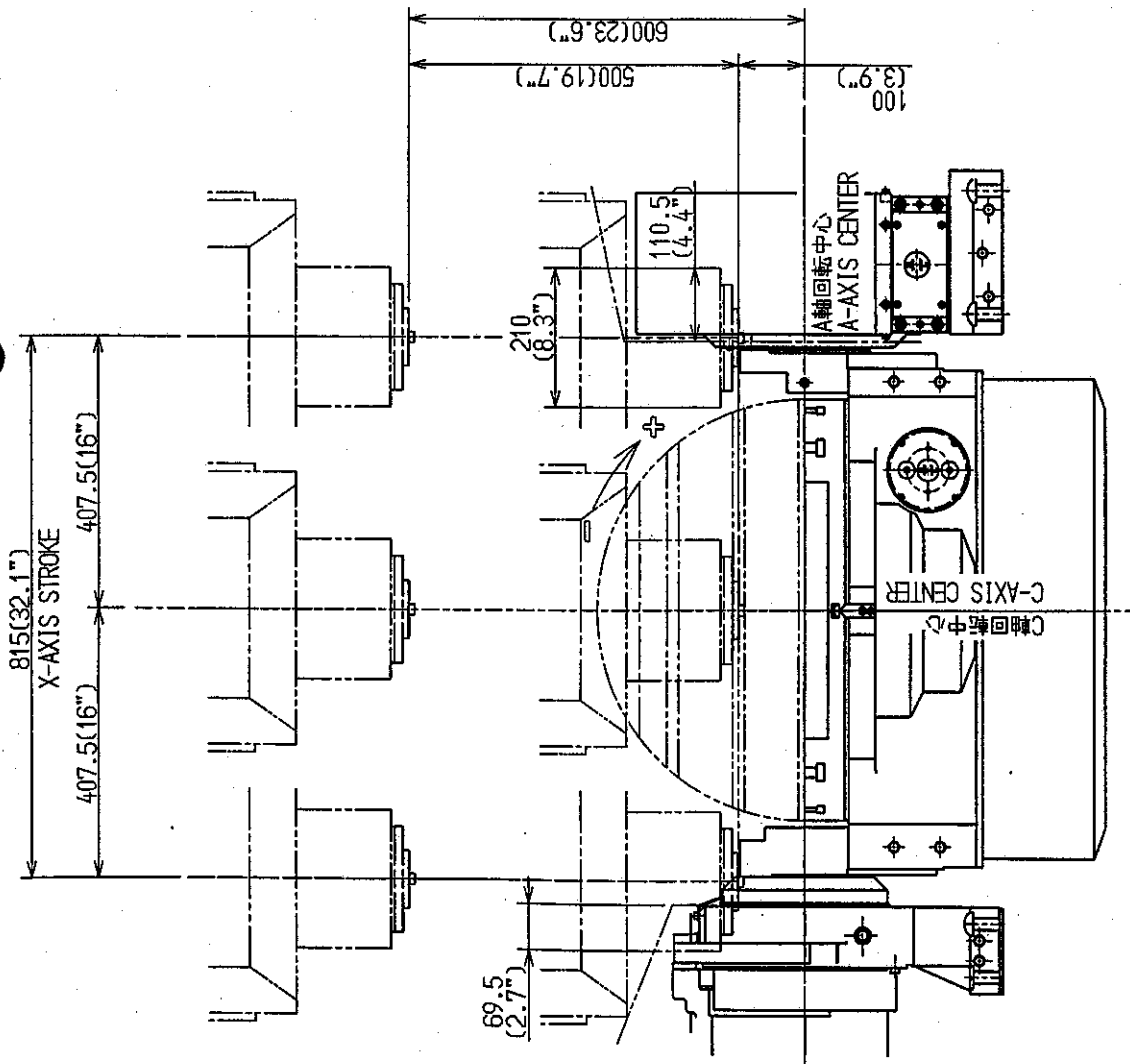

作業側ヨリ見ル

View from operator side

X-Z運動範囲
X-Z TRAVEL

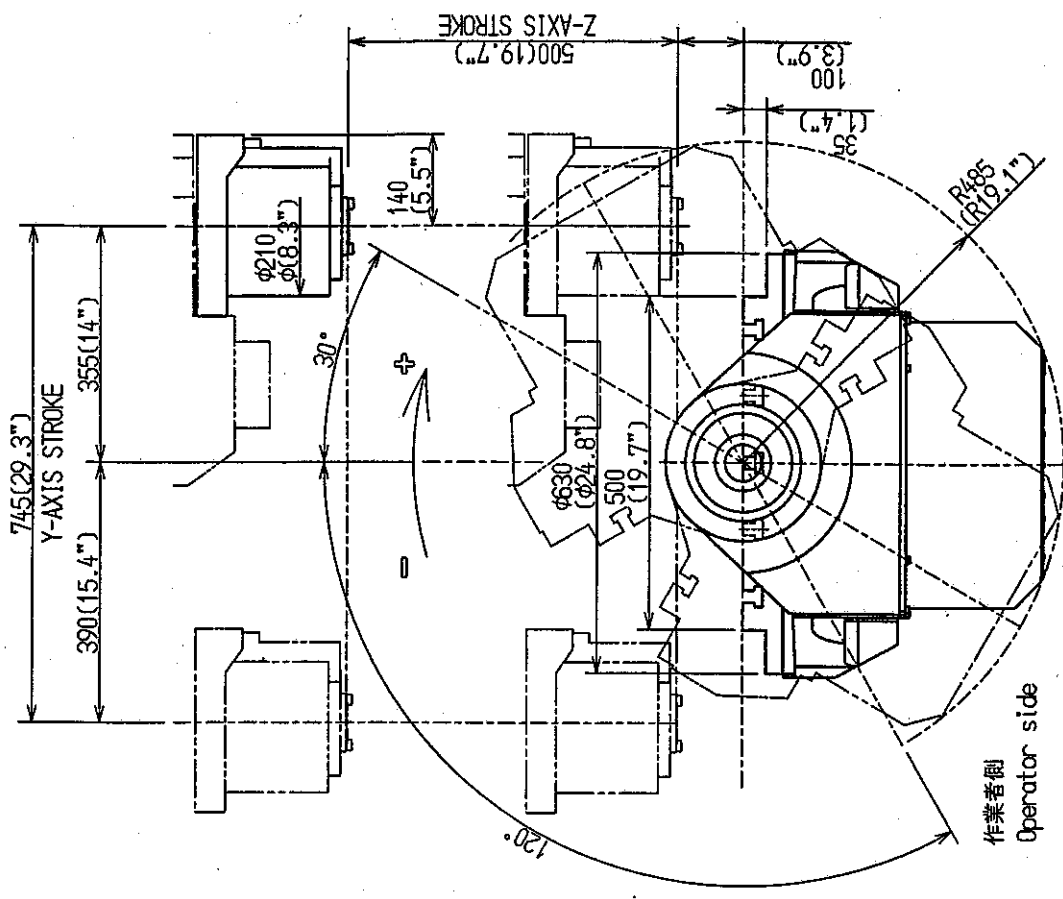

作業側
Operator side

Y-Z運動範囲
Y-Z TRAVEL

KITAMURA MACHINERY CO., LTD.
Mytrunnton

2.6. Name of parts

1. Z-axis scale
2. Y-axis servo motor
3. Spindle head
4. Tool magazine
5. Control box
6. Rotary Table
7. Cutting fluid tank
8. Cutting fluid pump
9. Bed
10. Y-axis scale
11. Cross rail
12. Numerical control device
13. Operation box
14. Spindle Motor
15. Z-axis servo motor
16. Role cover
17. X-axis scale
18. X-axis servo motor

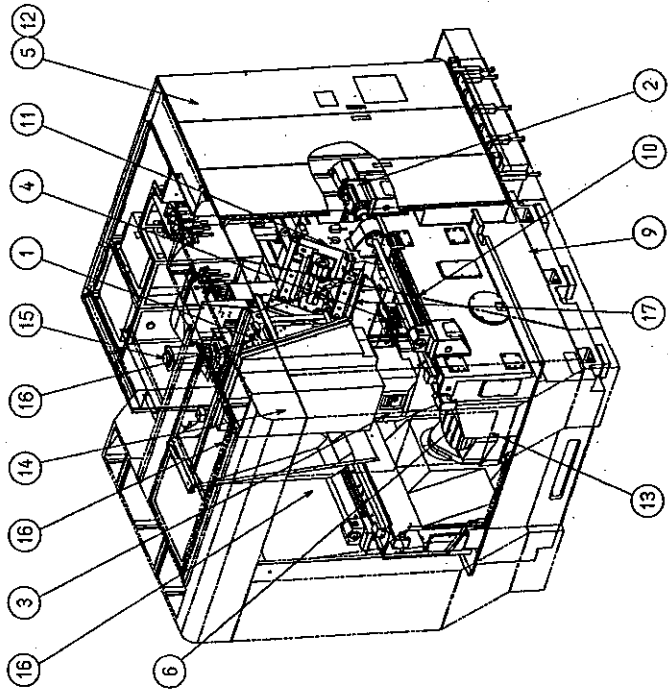
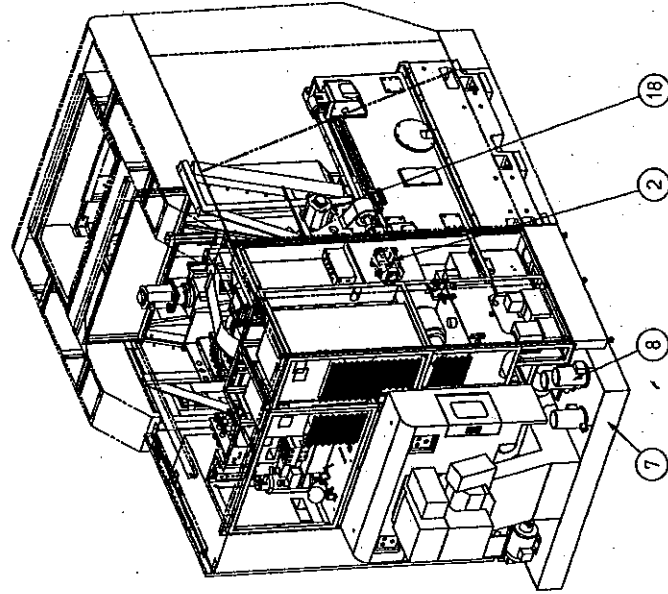

NAME OF PARTS 各部の名称
KITAMURA MACHINERY CO., LTD.

7/30/CH-TRIMMIDH-7 03/02/07

3. Installation

3.1. Lifting the machine

Life the machine with the lifting hooks as shown in fig 3-1. Follow the instructions below carefully.

- (1) Be sure to use a crane or chain Block with a capacity of over 17,400 kg (38,280 pounds) when slinging the machine.
- (2) Be sure to use a wire rope that can with stand the machine weight adequately.
- (3) Hook one side of wire rope to the front of the bed, and the other side to the one at the rear of bed. After installation, make sure that the hooks take off.
- (4) Be sure that the wire rope does not damage the column, table or covers by inserting wooden or felt protection.
- (5) Before full lifting, lift the machine a little and make sure that the machine is lifted evenly with the wire rope.

2020/04-1165-1006-11
 17.400kg

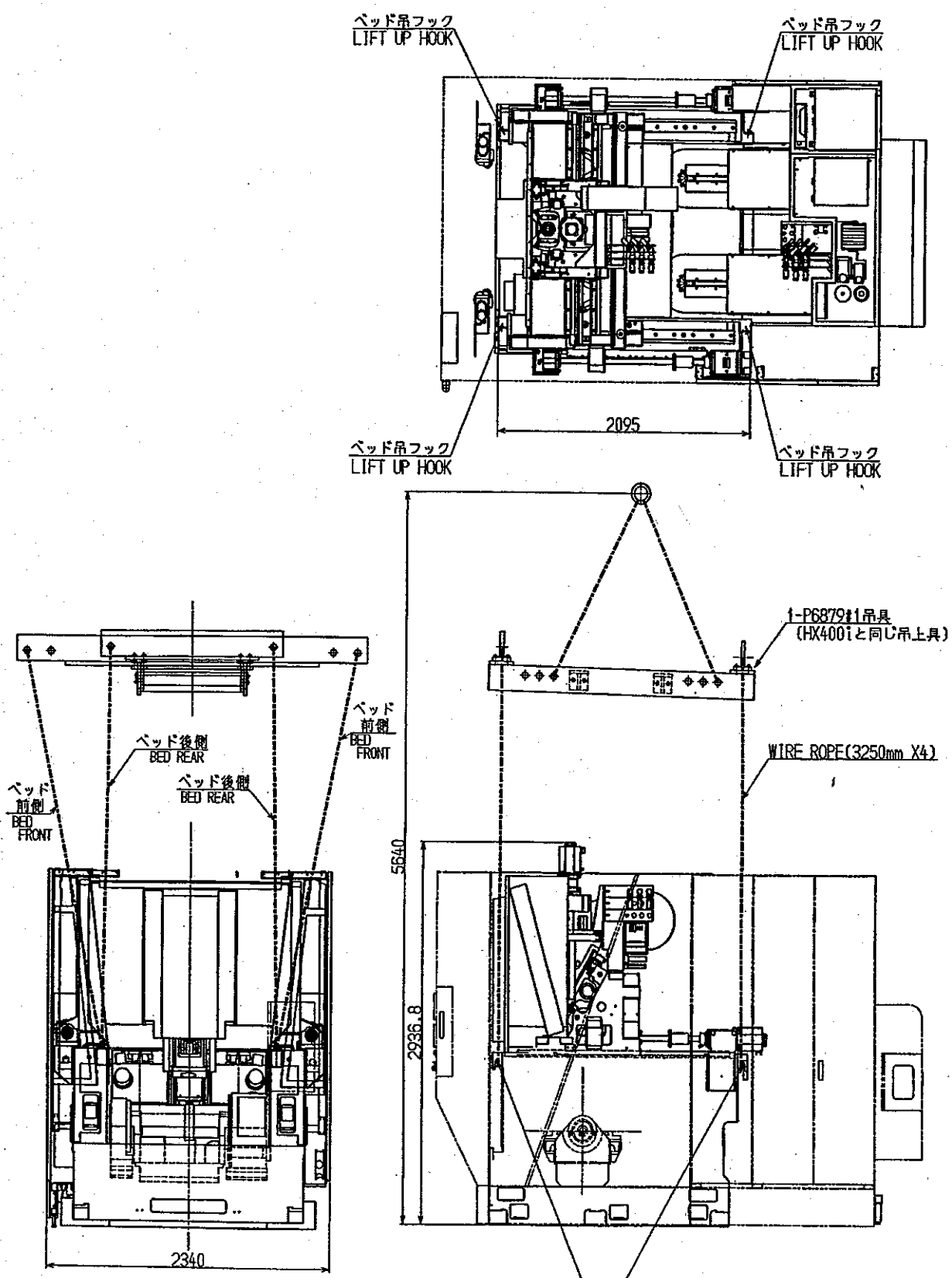

ベッド前後のフックにワイヤロープを掛けてください。
 Put the wire rope on the hook before and behind the bed.

MACHINE WEIGHT: 17,400kg (38,280pounds)
 NOTE: Machine weight and a center of gravity differ with the machine specifications.
 注: 機体重量とその重心は仕様値により異なります。

Fig3-1 Lifting the machine by wire rope
 図3-1 吊り具による機械の吊上げ

(Hytrunion/JIScenter-5 S/H10003-)

3.2. ELECTRICAL CONNECTION AND GROUNDING

After installing the machine, carry out electrical connections between the machine proper and control box, while fitting ducts and pendant arm.

All wiring is done using connectors. Make connections by matching the same symbols.

Next, connect power supply to machine proper at lower left of the back of the column. Connect power supply to L1, L2 and L3 terminals and earth lead to E1, terminal.

NOTE) AC 200 / 220V 3 phase 50 / 60(Hz) should supplied as machine power, R2, S2, T2 terminals.

- (1) Input power (L1, L2, L3): greater than AC 220 (V)
3 phases 50 / 60 (Hz)

Input power is transformed to AC 200 / 220 (V) 3phase 50 / 60 (Hz)
(R2, S2, T2) by TRANSFORMER.

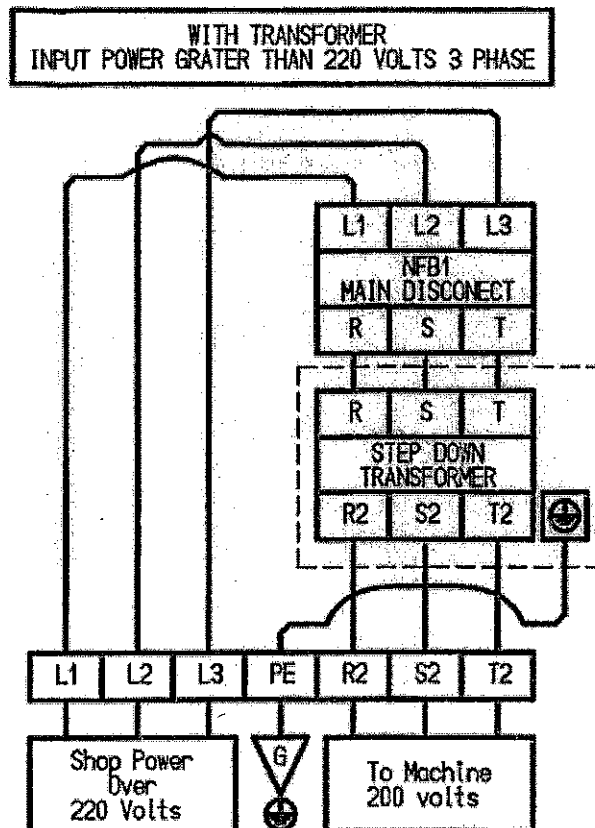

(2) Input power (L1, L2, L3) : AC 200 / 220 (V)
3 phases 50 / 60 (Hz)

TRANSFORMER is not necessary.

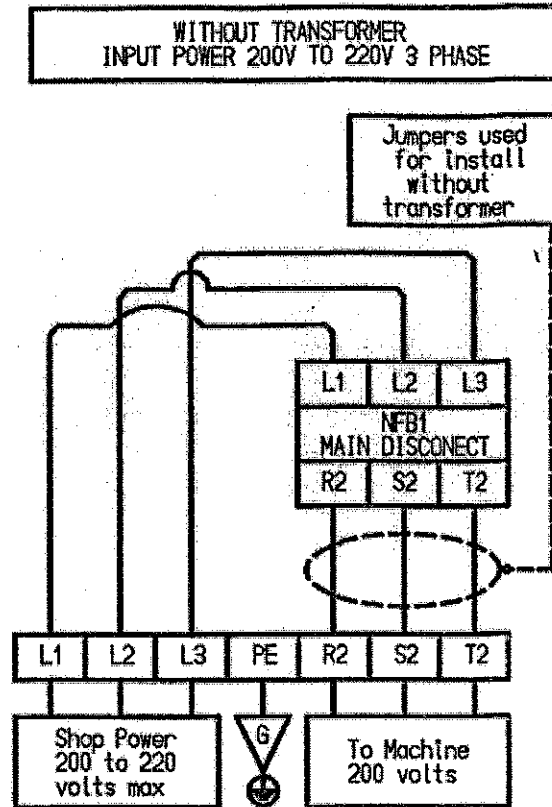

After completing electrical connections, check power phase. In the first place set the main power switch (no-fuse breaker NFB1) to ON. Push the magnetic switch MS2 with a driver, and the coolant pump begin to revolve.

Check if the motor revolves in direction indicated with the arrow or not.

If it rotates in the reverse direction, change any two connections of L1, L2 and L3.

3.3. Foundation Base

Be sure to install the machine in a place isolated from toll grinders that disperse polishing power, or compressors or other machine that vibrates.

The foundation base must be carefully and correctly set, as it will affect to accuracy of machine.

The level and balance and firmness of the foundation base depend on the ground conditions. Be sure to prepare a strong base set in concrete to prevent land subsidence after installing the machine.

This is information for reference purposes, but at least the concrete base shown in the plan.

3.4. Cleaning

Carefully wipe off the preventive rest compound applied to parts, using lint-free rags and solvent such as benzine or kerosene. Clean the table surface and guide way with special care to remove dust and any other foreign matter completely.

3.5. Installation

For top machine precision and to insure long life, some adjustment will probably be necessary.

Install the machine according to the following procedures.

Preparatory Installation Measures

- (1) Place the plate for adjusting level on the position designated on the machine.
- (2) While lifting the machine, insert from below the foundation bolts into the holes provide on the bed, and attach a nut to each bolt.
- (3) Carefully lower the machine into the foundation.
- (4) Carefully rough leveling the machine on the table, pour mortar into the foundation bolt holes and level the machine in the same position for a few days until mortar is slowly dried.

Leveling

After motor is dried completely, critically examine level of machine.

- (5) The accuracy of the level must be 0.02mm per 1000mm.
- (6) Level the machine using jack bolt. Examine level at center and both ends of table as shown in fig3-2.
- (7) After completing adjustment of level, tighten the foundation bolts securely.



图 3-2
Fig. 3-2

3.6. Important on machine accuracy

In regard of machine installation, the following conditions should be achieved so that we could guaranty a sufficiently good accuracy.

Condition for the machine installation		H series (high accuracy model) or cutting accuracy required within 5 μ m
1	Temperature in the place of machine	20°C \pm 1°C
2	Humidity in the place of machine	60% \pm 5%
3	The difference in ambient temperature for 24 hours	0.5°C
4	Temperature gradient	within 0.2°C / hr
5	The difference of ambient temperature between the floor and 5m height	0.7°C
6	The machine is to be free of direct sun Light	
7	The machine is to be free of direct blow of warm or cold wind	
8	The foundation of machine is to be more than Kitamura recommends	
9	The machine is to be free of outside Vibration	
10	The distance between the top of the machine and the roof of a room	More than 1.5m
11	The durability of foundation for the machine is more than 0.098Mpa (10t/m ²)	
12	Difference between foundation floor side temperature and room temperature.	0.5°C

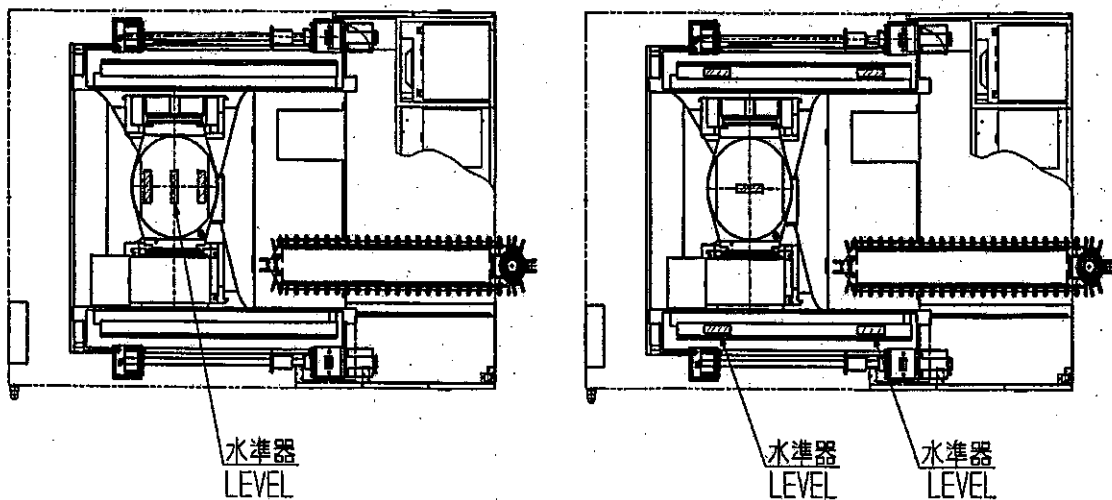
13. When filling the machine with coolant, a water-based coolant (Synthetic fluid, Emulsion oil, Soluble oil, etc.) should be used.

An oil-based coolant should not be used on the High Accuracy Machine. Using an oil-based coolant can lead to overheating in the coolant pumps. Also, the temperature of the coolant will rise causing the machine to decrease in accuracy.

If you must use an oil-based coolant then you must also have a coolant cooling system installed, and coolant pumps that are specifically designed to handle the oil-based coolant. The coolant temperature should be maintained at 20°C (68°F).

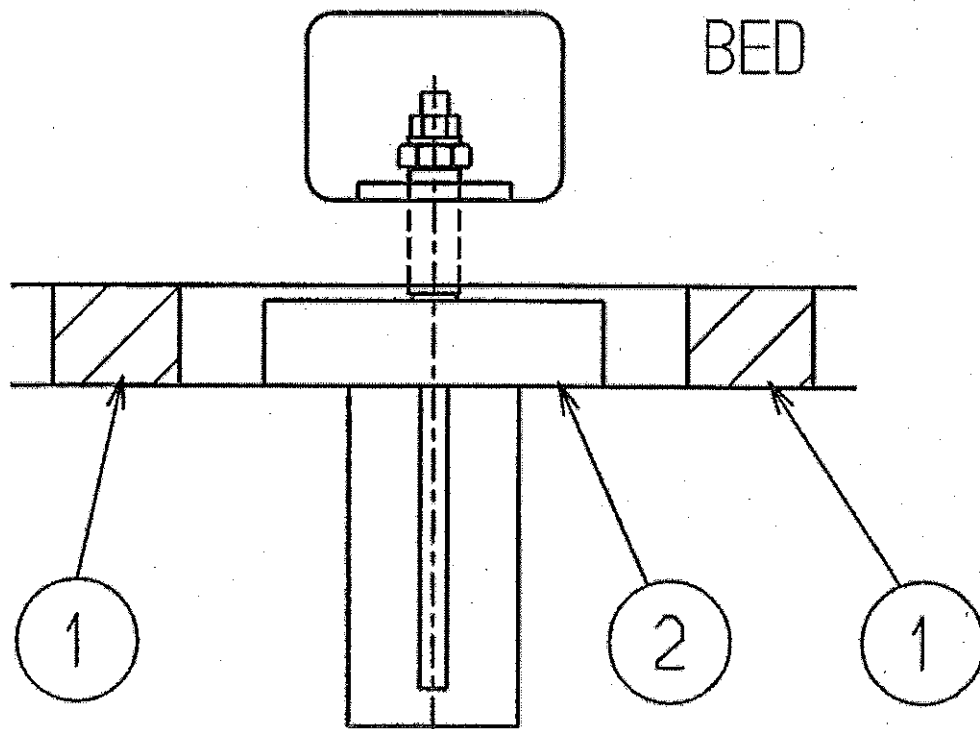

NOTE) Before the machine is totally set on the ground, place the machine on some blocks (NO.1) at first, and obtain the machine level there on a temporary basis. After leveling, insert the foundation bolt into the foundation hole through the foundation plate (NO.2) and then fill in with mortar. 4,5 days later when the mortar has become hard, level the machine once again but this time, more thoroughly. Then, remove the blocks a the final procedure for machine settlement. (Here, please make sure that the foundation plate (2) will not fall into the foundation hole nor be tilted.)

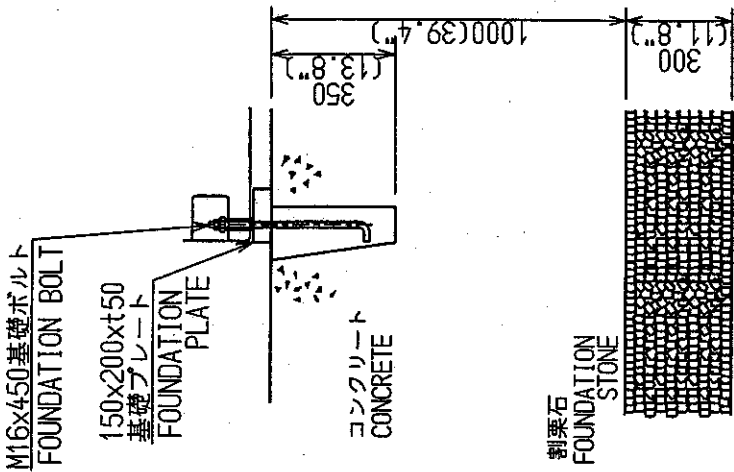

SEC AA

• 本図ノ地耐力ハ10ton/m²デス
 地耐力ガ不足スル場合、
 増強施工ヲ行ッテ下サイ。

Soil bearing capacity
 of this drawing is 10ton/m².
 When soil bearing capacity
 is insufficient, the reinforcement
 construction is done.

• 基礎上面ノ水平度ハ、5mm以内ノコト。
 The levelness on the base is
 within 5mm.

• 基礎ノ設置ハ機據据付開始前
 1ヶ月以前ニハ必ず行ウコト
 Set up the foundation base
 one month or more before
 the installation of the machine
 is started

100ATC

S003-013-4

Mytrumnion FOUNDATION DIAGRAM 基礎図
 KITAMURA MACHINERY CO., LTD.

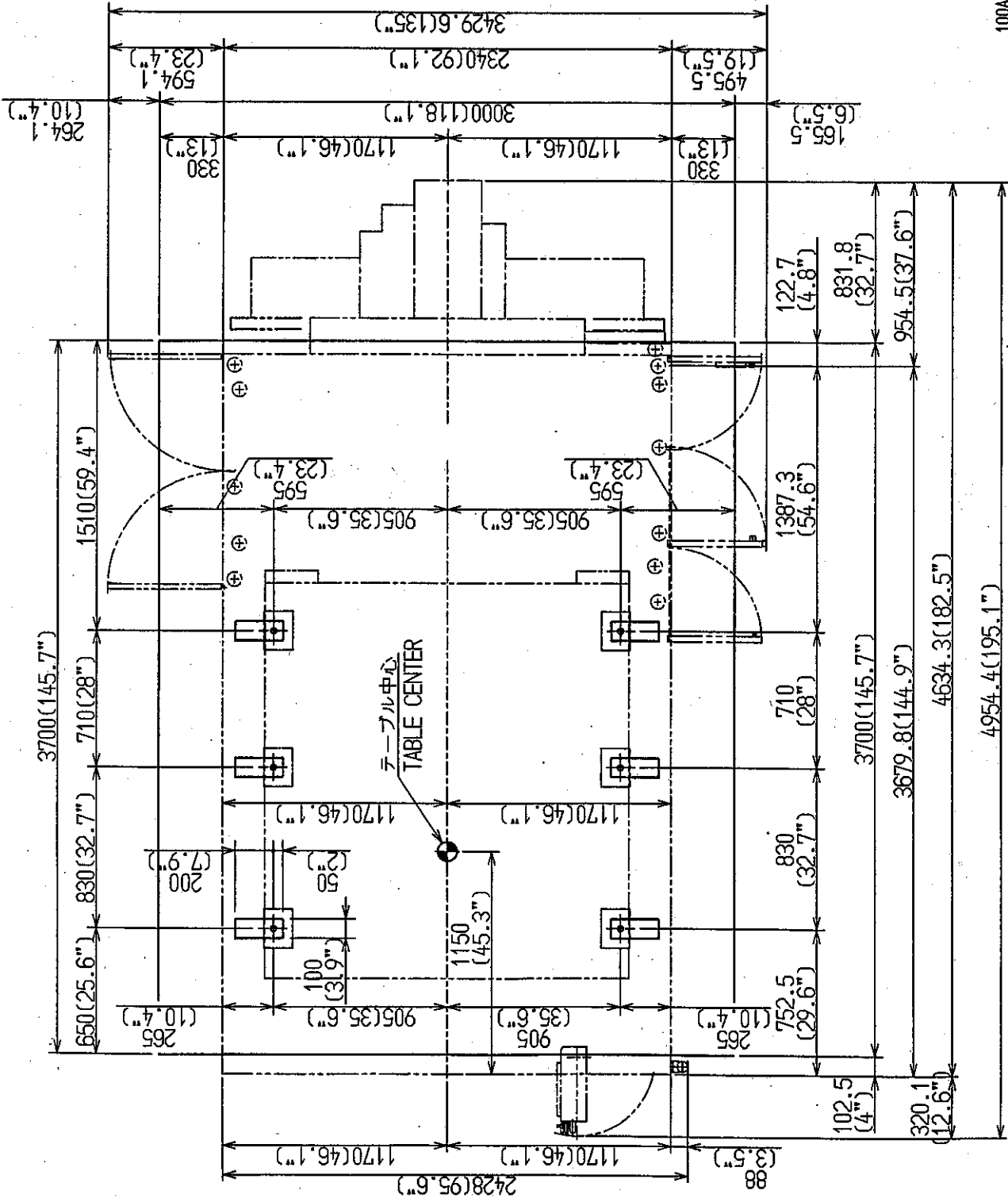

• 本機ハ早速リガ高速ノ為、必ず基礎ボルトニヨル機械ノ固定ヲ行ッテ下サイ。
 Anchoring the machine on a rigid foundation is strongly recommended.

NOTE

1. This durability of foundation for this machine is 0.098Mpa (10 ton/m²), install this machine in the place according with the durability.
2. In the case of the installation, use the foundation bolts and foundation plates without fail which are the optional accessories of the machine.
If the foundation bolts and the foundation plates no use, it will be no sure of accuracy.
3. Take away something which vibrates near the place of installation and, not install in the place where this machine gets much sunshine from the windows.
4. For foundation, please prepare a rigid foundation according to our foundation plan and fix the machine tight by the use of anchor bolts.